

# Practice Guide – Cooling (Lot scale)

## Using water to cool residential outdoor spaces

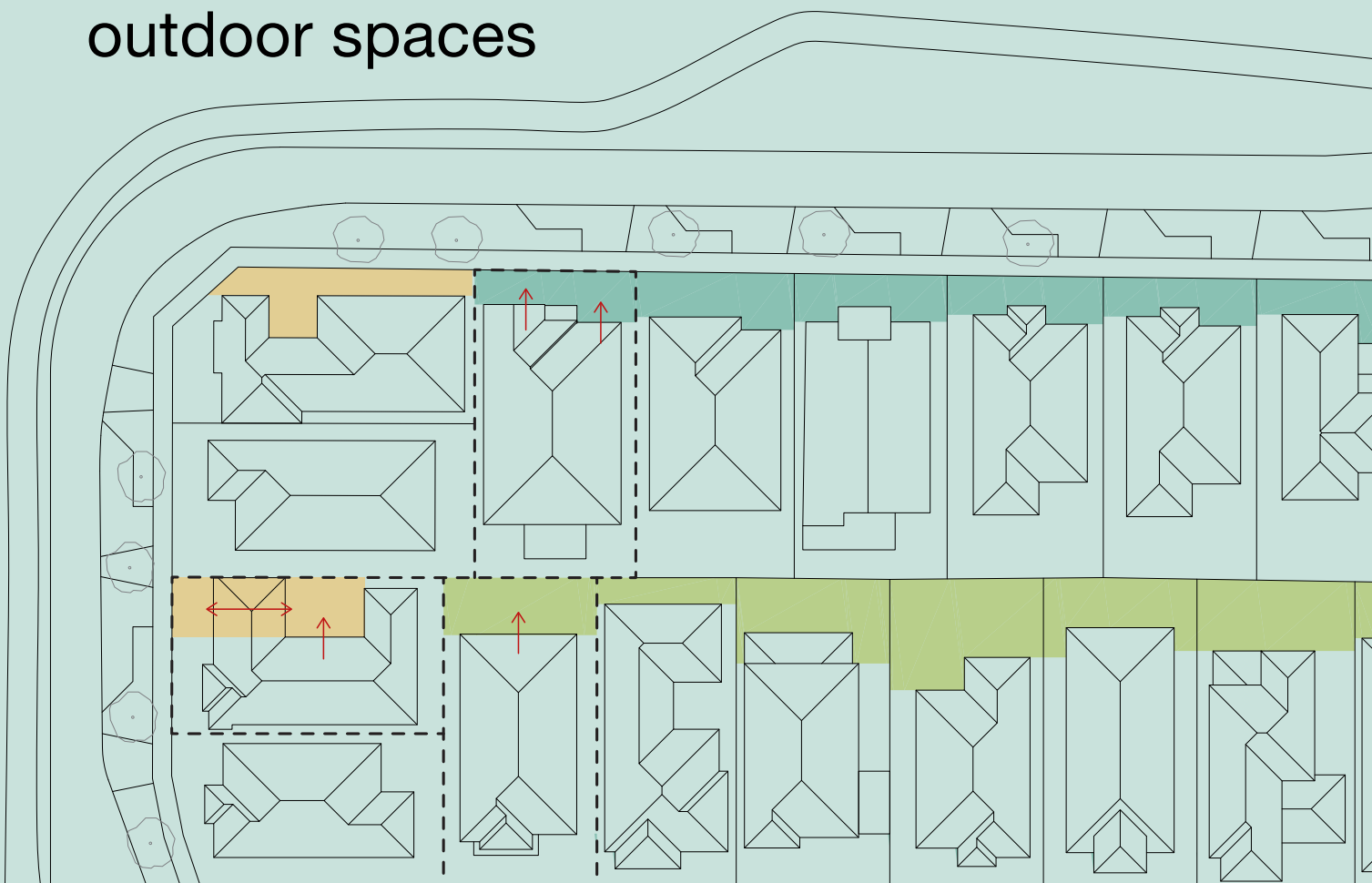

MONASH  
University

MONASH  
SUSTAINABLE  
DEVELOPMENT  
INSTITUTE



Water Sensitive Cities  
Australia



THE UNIVERSITY OF  
MELBOURNE

**N  
M  
B  
W**

COOLTH  
INC

South East  
Water

This practice guide showcases good design for cooling outdoor living spaces using water, plants and architecture. The guide was developed by South East Water, University of Melbourne, Water Sensitive Cities Australia, NMBW Architecture and Coolth Inc.

Our aim is to raise awareness of cooling using water, providing both public health and environmental sustainability benefits. This guide focuses on the places where these cooling benefits are needed most: outdoor areas around our homes. It introduces evidence-based cooling principles and outlines practical ways to achieve good design.

## Practice Guide – Cooling (Lot scale)

July 2023

© 2023 Water Sensitive Cities Australia

### **Publisher**

Water Sensitive Cities Australia  
PO Box 8000  
Monash University LPO  
Clayton, VIC 3800  
e. [info@wscaustralia.org.au](mailto:info@wscaustralia.org.au)  
w. [www.wscaustralia.org.au](http://www.wscaustralia.org.au)

Please cite this report as: Water Sensitive Cities Australia (2023). *Practice Guide – Cooling (Lot scale)*. Melbourne, Australia: Water Sensitive Cities Australia.

### **Disclaimer**

Water Sensitive Cities Australia has endeavoured to ensure that all information in this publication is correct. It makes no warranty with regard to the accuracy of the information provided and will not be liable if the information is inaccurate, incomplete or out of date nor be liable for any direct or indirect damages arising from its use. The contents of this publication should not be used as a substitute for seeking independent professional advice.

# Contents

Cooling with water	4
How does water provide cooling?	5
Designing a cool garden	10
Tools for cooling	14
Plants for cooling	17
Front yard, backyard and court yard examples	20
References	25

# Cooling with water

Finding effective ways to keep cool over summer is important for our health and comfort. Finding *sustainable* ways to stay cool is important for the planet.

This guide demonstrates how to use water wisely to create cool, comfortable outdoor areas around the home. While other guides discuss energy efficient home cooling, this guide is different because it focuses on outdoor areas. It draws on research by the University of Melbourne, South East Water and the CRC for Water Sensitive Cities to demonstrate how to keep cool sustainably, using water.

The cooling solutions in this guide are a great choice for anyone wanting to use their gardens on very hot days: active families, people who like outdoor entertaining or people who enjoy working or relaxing in their gardens.

Creating a cool garden is easy. It involves combining water, plants and architecture to create natural shade, cool the air and cool the ground. Smart technologies can also help maximise the cooling effect.

The guide focuses on low-density residential development across Melbourne. In these situations, designing a cool garden can influence the initial planning of a new house and land package. For instance, designing cool garden zones and internal living zones at the same time creates opportunities to rethink house design, using cool gardens to extend available living areas on hot days.

Cool garden ideas can also be used for existing suburban homes, or in cities with similar climates.

# How does water provide cooling?

Using water to create cool outdoor spaces is an effective way of coping with urban heat and the very hot days that are a regular feature of Melbourne summers. So, how much do we understand about urban heat and how we can use water effectively to manage it? Below, we summarise the science on this topic.

We can describe 'heat' in several ways:

- › Surface temperature – how hot surfaces (e.g. roads, walls, fences) are to touch
- › Air temperature – the temperature of the air around us
- › 'Feels like' temperature – how hot we feel. This is influenced by the temperature of surfaces and the air around us, as well as humidity, radiation and wind: the windier it is, the cooler we feel; the more humid it is, the warmer we feel.

## What is urban heat?

Urban heat refers to the way that heat builds up in cities. This occurs because cities have replaced natural and rural vegetation with pavements, roads, buildings and other hard surfaces that are very good at storing heat. The lack of trees in cities means there is less shading and less evapotranspiration to keep us cool. In addition, there is more waste heat from infrastructure and vehicles. All of this heat is stored in these hard surfaces and then radiates back to increase the effect of a hot day.

Extreme heat stress can be fatal (e.g. DHS, 2009; Loughnan et al, 2013), and more people die in Australia from heat stress than all other natural disasters combined (Coates et al, 2014). Heat stress is particularly dangerous for young children, older people and people with health conditions like heart disease, diabetes and mental illness (Rey et al, 2009).

## Why is managing urban heat important?

Urban heat is uncomfortable at best, and deadly in the extreme. A good way to think about this is the stress that heat puts on our bodies. Heat stress also affects other plants and animals in cities, as well as how well a city's infrastructure functions.

Reducing heat stress is therefore an important issue for urban planners. And even small temperature reductions during a heat wave can save lives, such as reducing the stress level from extreme to a lower level. For example, reducing the average overnight temperature in Melbourne from 30° to 28°C could save 1 person per 100,000 people (Nicholls et al, 2008).

Heat stress levels range from extreme stress to no stress. These levels are based on the 'feels like' temperature, which measures how hot we feel (Nice, 2021).

Heat stress also affects our comfort, how well we sleep and how productive we are at work. It also affects infrastructure (e.g. train lines (McEvoy, 2012)) and natural ecosystems in urban areas. An economic assessment of effect of urban heat on the City of Melbourne (Aecom, 2012) found a range of significant impacts on health, transport operation and infrastructure, energy demand and infrastructure, trees and animals, and crime. So, cooling has benefits, even when the heat stress level is not extreme.

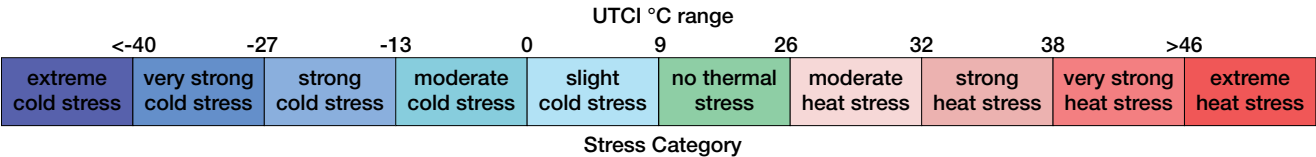

Figure 1. The Universal Thermal Climate Index (UTCI) expresses temperature in levels of outdoor cold or heat stress

## How can we manage urban heat?

Heat affects the whole urban landscape, but its effects are felt most at a local scale (Coutts et al, 2013). For this reason, cooling solutions are designed across a range of scales:

1. altering how we design our suburbs (e.g. adding more local parks)
2. changing the indoor and outdoor features of our houses (e.g. planting trees to create shade)
3. keeping ourselves cool on hot days (e.g. helping the natural body process of sweating which transfers heat as sweat evaporates).

There is a growing focus on managing urban heat impacts in our workplaces and homes (Jay et al, 2020), and this is where the new generation of urban design solutions lie.

## Can cooling our homes make a difference?

Cooling actions are more effective when they target smaller areas, like backyards, than when trying to cool an entire city. This is good, because these areas are already well suited to this purpose. Residential back and front yards comprise 20% of urban areas but have much higher percentages of tree canopy and groundcover compared with other urban areas such as streets or shopping strips. This makes suburban yards among the coolest land use areas in Australian cities (Ossola et al, 2020). Good cooling design can maximise this effect with little additional effort.

## How can we keep our yards cool?

Keeping our yards cool can encourage us to use the spaces more often. Factors such as the quality and functionality our yards affect how we use them. In turn, these factors are influenced by spatial organisation and design of outdoor spaces.

A cool garden strategy combines water, plants and architecture to enhance the quality and functionality of outdoors space on very hot days. A good design helps these elements work together to create the best cooling effect.

## What is water's role in cooling?

Three ways water provides cooling in a cool garden are outlined below (e.g. Figure 2, which shows mean daily temperature reductions):

### 1. Healthy plants

Water is key to healthy plants, and healthy plants are the basis of cooling. Plants in a cool garden are selected for their shade and their evapotranspiration properties, as well as their aesthetic, health and biodiversity benefits. Having more green spaces (i.e. lawn areas) and less hard areas (i.e. concrete) reduces the build-up of heat around our homes. Plants provide shade and also cool the air through evapotranspiration – i.e. the loss of moisture from leaves (Coutts and Tapper, 2017). For example, the air temperature below a shady tree on a summer's day can be 1.2°C cooler than out in the open, and a fully shaded street can be 0.9°C cooler than a street without trees (Coutts et al, 2015) (These are the mean daily temperature reductions). And the combined cooling effect of adding trees, groundcovers and turf to residential lots adds up, as demonstrated in studies such as Ossola et al (2020).

### 2. Extra irrigation

Conventional household irrigation takes a simple approach to applying water to a garden. It aims to replace soil moisture lost to evaporation, so plants can grow. But this simple approach doesn't always provide the right amount of water, at the right time, to get the best cooling effect.

By contrast, irrigation for cooling intentionally uses more water to sustain higher levels of soil moisture for plant growth as well as increasing evaporation. The extra water provides cooling in 2 ways:

- Sustaining higher levels of soil moisture increases daytime evapotranspiration. This cools the ground and the air above.
- It keeps trees and plants healthy on the hottest days. Well-irrigated plants have less leaf stress and provide more shade and evapotranspiration that cools the air.

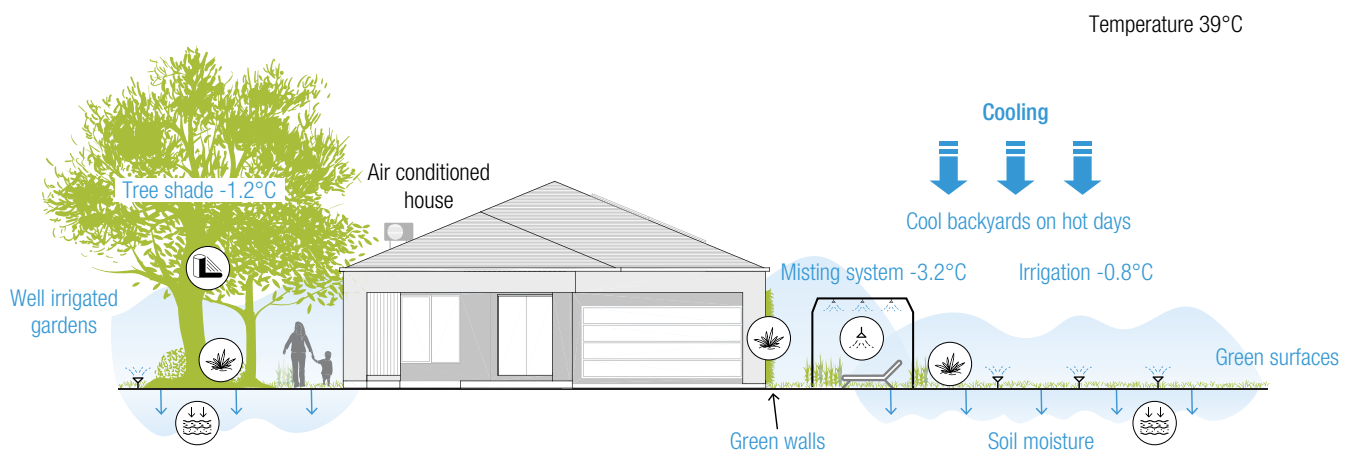
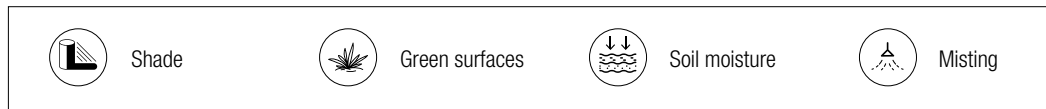
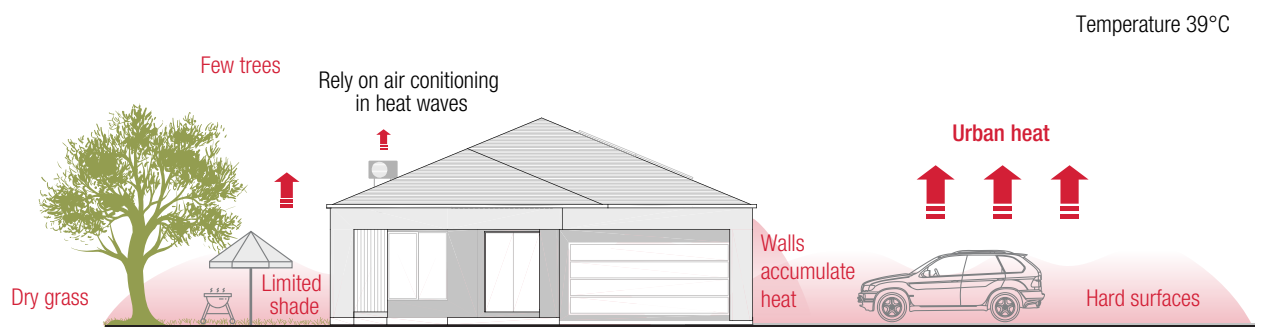

Figure 2. Cool gardens combine water, plants and architecture to create comfortable outdoor areas. This figure shows realistic mean daily temperature reductions on a hot day in Melbourne. Instantaneous reductions can be even greater.

These effects are measurable. Irrigation for cooling can reduce instantaneous daytime air temperatures by 2.0°C, and the average daytime temperature by 0.8°C (Cheung et al, 2022b). This effect can be even stronger in hot, dry climates. For example, irrigating green spaces in Adelaide could reduce the daily average air temperature by 2.3°C (Broadbent et al, 2017).

Being water efficient is still important, but the aim is not just to have a drought tolerant garden that uses as little water as possible. Irrigation for cooling can be optimised using smart controls that respond to the level of rainfall and soil moisture, ensuring water is not wasted.

### 3. Add misting

Water can also be introduced to cool gardens using misting systems. Misting is like outdoor evaporative cooling, if you don't mind getting a little wet. It uses very fine water droplets to wet the skin, creating evaporation that instantly cools the body down, much like the way we sweat when we get hot. It is very water efficient and only small amounts of water are needed to get these cooling effects. Research at the Aquarevo House shows misting instantaneously reduces the air temperature by up to 3.2°C, even though the effect is short-lived once the misting stops (SEW, 2023; CRCWSC, 2018). This cooling is enough to reduce the level of heat stress experienced on a summer's day (measured on the UCTI scale).

## What about water conservation?

Being water efficient is important, and action begins at the household scale.

Research at Aquarevo House and University of Melbourne trial sites shows the ideas of water efficiency and water for cooling can coexist. We can achieve a cool backyard using water efficient spray irrigation and misting systems. For example, the research found irrigating 1 mm 4 times over an afternoon cools the air temperature more than irrigating 4 mm all at once.

We can also use these systems together with smart controls that turn on only when needed. For example, the smart irrigation system developed for Aquarevo accounts for rainfall and soil moisture content.

## Which water source?

Another way to conserve precious drinking water is to use sustainable water sources for cooling, if possible and when it is safe to do so. The Aquarevo smart irrigation system is designed this way. It uses rainwater to irrigate the garden first, and then switches to Class A recycled water when rainwater runs out. For health and safety reasons, the Aquarevo misting system uses only drinking water.

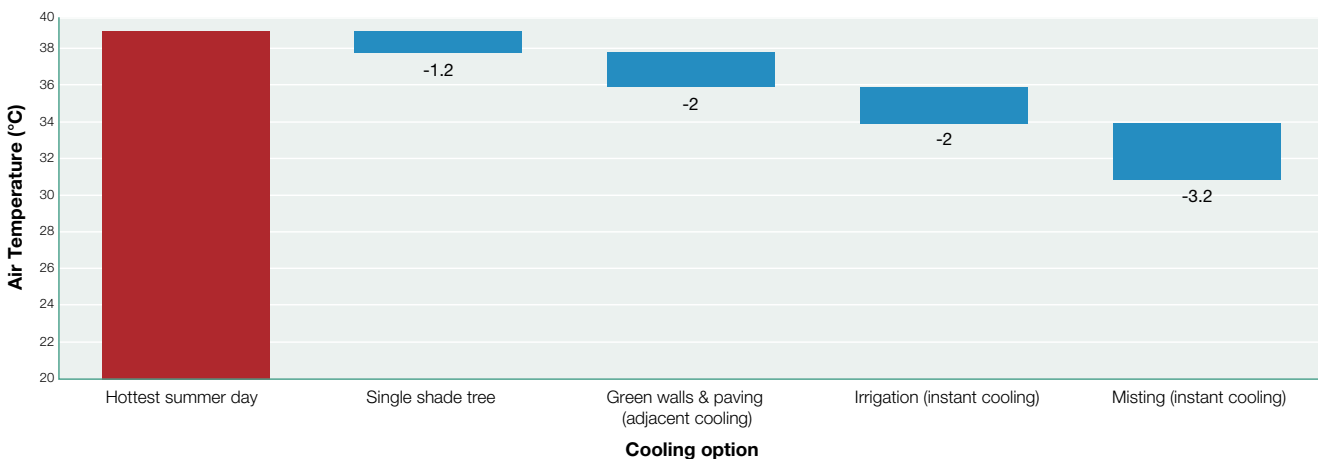

Figure 3. Lot-scale cooling options<sup>1</sup> and their cooling effect (blue<sup>2</sup>) on a hot summer day (red), using Melbourne's<sup>3</sup> hottest 2022 summer day as a benchmark. This figure shows instantaneous temperature reductions.

- (1) BOM (2023); (2) Cheung et al (2022a); (3) Coutts et al (2015); (4) Osmond and Sharifi (2017).
- The cooling effect of each option is based on comparison with a barren/unirrigated/unshaded equivalent; the effect is generally quite localised.
- Results will vary from city to city.



## These ideas are great. How much cooling is possible?

Cooling is best measured by air temperature. Evaporative air conditioning lowers indoor temperatures by 10°C (Osmond and Sharifi, 2017). By comparison, using shade, irrigation and misting we can realistically reduce air temperatures across a city by 2°C. Bigger cooling effects are possible in individual parks and backyards (Sydney Water and UNSW, 2017). Combining individual cooling actions increases the overall effect.

The aim is to reduce extreme heat stress on very hot days, and this is realistic for small areas like cool gardens.

## Why cooling with water is better than using air conditioning

During extreme heat waves the safest place to be is indoors, in air conditioning (Bouchama, 2007). But air conditioning is not always our friend at other times. As well as trapping us indoors, always relying on air conditioning for cooling has several disadvantages compared with shade, irrigation and misting (Jay et al, 2020):

- It's expensive, with high upfront and running costs.
- It's not environmentally sustainable:
  - It produces waste heat that compounds the urban heat effect.
  - It increases demand for electricity, and even exacerbate electricity shortages during heatwaves.
- People who spend a lot of time in air conditioning become less acclimatised to heat waves.
- Using air conditioning to compensate for poor dwelling design leaves residents vulnerable during power blackouts. These houses quickly become unliveable without air conditioning.

# Designing a cool garden

A cool garden can be designed in 5 steps that combine the cooling abilities of water, plants and architecture:



## Step 1 – Choose a location

While it's possible to cool the entire garden, it is easier to cool a smaller area.

A starting point is to choose an area where you would like to spend more time on hot days. (Tip: Think about an activity that you'd like to spend more time doing on a hot day.)

A suggestion is to create your cool zone next to the house. This helps to blend indoor and outdoor living areas, extending the total living space on hot days. Other options might be to cool garden areas used for entertaining, relaxing or even for active sports.

Another way to choose a location is to consider your house and block together. Three options to consider are:

1. **Front yard cool zones.** Front yards often have extensive garden beds and trees that can be designed and irrigated to provide cooling.

If everyone on a street uses their front yards, this can increase the sense of community in new developments. Some homes face onto attractive parks and a cool front yard can harness these amenity benefits.

### Some other factors to consider are:

- Neighbourhood character. Does your cool garden complement other houses on the street?
- Privacy. Greenery installed a part of a cool garden helps create privacy as you enjoy your cool front yard.

2. **Backyard cool zones.** Backyards are a staple of Australia suburban living. They offer privacy and security, and are often well suited to shade trees.

Backyard cool zones can be designed by combining features such as outdoor kitchens and entertaining areas with cooling tools such as turf areas, raingardens and shade trees.

These cooling tools are described in the next section of this guide.

### Another factor to consider is:

- Wind. Opening up the space for gentle breezes and air circulation adds to the evaporative effect and the sensation of cooling.

3. **Courtyard cool zones.** For some houses, the courtyard might be the ideal spot for a cool garden.

Conventional courtyard design uses lots of hard surfaces, and these areas can have poor airflow. Courtyards are ideal for installing arbours, green walls, ground covers and overhead misting to reduce heat build-up during the day.

### Another factor to consider is:

- House layout. Can you use existing connections to outdoor areas to create new cool courtyard areas?

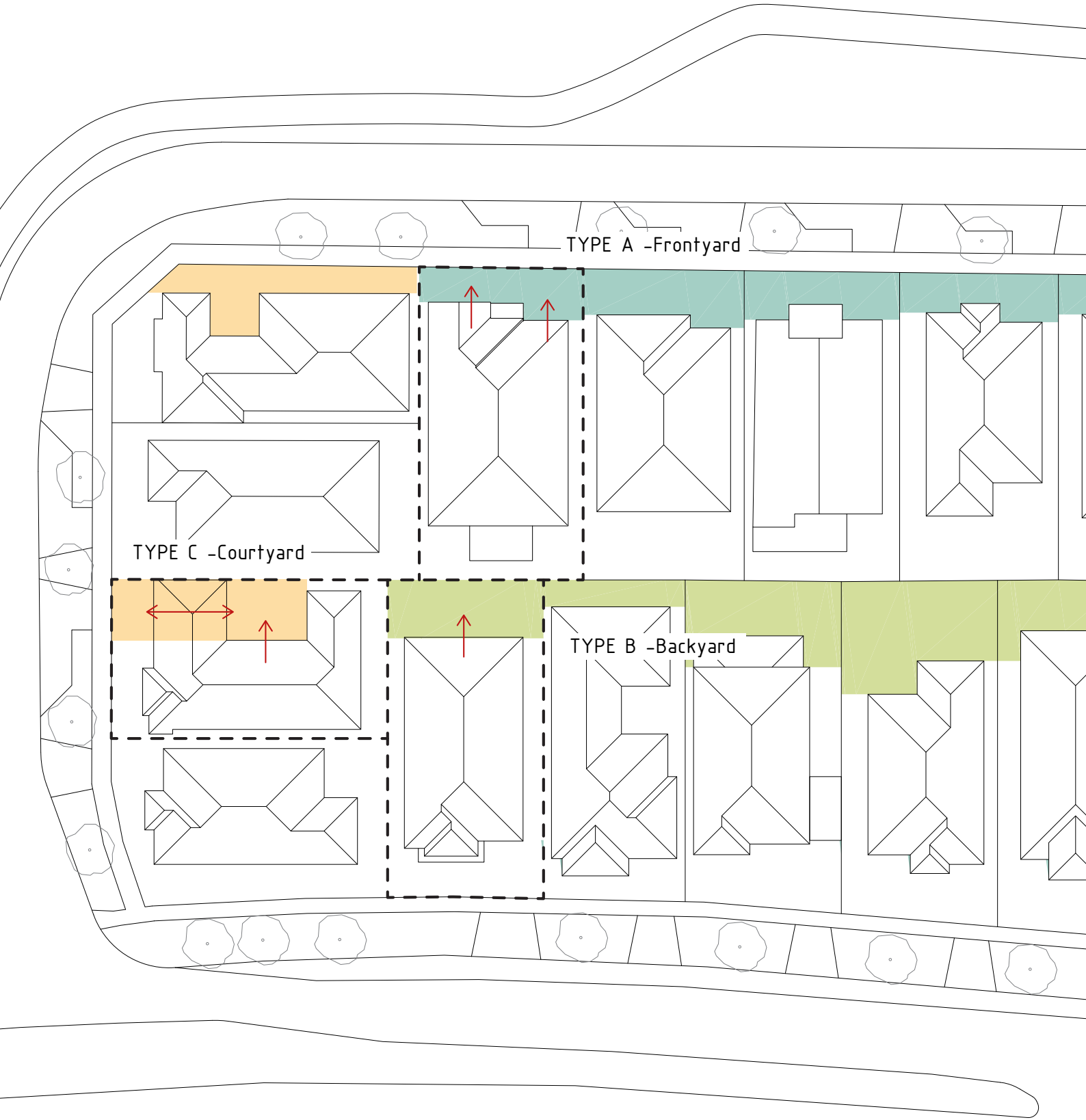
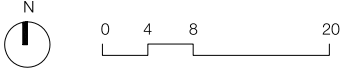

Figure 4. Cool yard location options



## Step 2 – Choose your architectural design

Architectural design refers to the built elements of your cool garden, the materials used and how different spaces connect together. The built elements can provide shade as well as a structure for plants to grow on. The architectural design also affects how water and air move through the space.

Five design tips:

1. **Minimise hard, heat absorbing surfaces.** In a cool garden design, it is best to avoid using materials that will absorb heat for walls, roofs and ground covers.
2. **Make room in the ground for plants.** Look for ways to include garden beds and deeper soil areas in the cool garden. You can even use walls and overhead structures.
3. **Provide shade.** Aim to shade the wall and ground surfaces that will absorb the most heat, such as paved areas and west facing walls. Ideally, plant trees to provide this shade. If it is impractical to plant more trees, architectural shading (such as shade sails or arbours) create a similar shading effect.
4. **Add other features that support cooling.** Provide sustainable water sources for irrigation systems, like water tanks, and provide structures for growing plants, such as pergolas and planter boxes.
5. **Create transitions between indoor and outdoor living spaces.** Use physical and visual connections that encourage the use of cool areas and extend indoor living areas.

### How can I use plants to enhance cooling with water?

Normally, we think of water supporting plants. But in cooling situations, we can also think of it the other way: how can plants enhance the cooling effect of water systems?

Consider the example of a courtyard with a west facing wall. On a hot summer afternoon, a person sitting in this space feels the intense, radiating heat from the west facing wall.

## Step 3 – Add plants

In a cool garden, plants provide shade as well as evapotranspiration to cool the air. Cool garden design is all about choosing the right plants for the right location.

Five design tips:

1. **What sort of garden do you have?** Choose plants based on your soil conditions and rainfall, what sort of plants you enjoy and how the garden is used (e.g. by active children, for food, for aesthetics).
2. **Select plants for their cooling abilities.** Some plants have better cooling ability than others. Select plants for:
  - Shade. The aim might be to shade the ground, a wall or people in these spaces. Not everyone wants shade trees, and that's fine.
  - Water use. Species that need more water also often provide the best cooling when combined with irrigation.
  - Night or daytime cooling. Different plants transpire at different times across the day. Choose a mix of species so that you can extend length of the cooling during the day.
3. **Position plants for their cooling effect.** It is useful to select plants that suit the aesthetics and function of the space you want to cool. Also consider how these plants can be positioned to create shade from direct overhead sun or to provide protection from radiant heat from ground coverings and walls.

A good way to cool the courtyard is to install a misting system. This quickly reduces air temperatures and cools the skin. But a misting system alone provides only momentary cooling, especially with the continuing heat radiating from the wall. It could even become quite humid in the courtyard.

Adding overhead plants, ground cover and even vertical green walls provides additional cooling. It reduces the heat radiation and perpetuates the cooling effect created by the misting system. These plants also provide aesthetic and environmental health and restoration benefits.

Positioning can also consider evapotranspiration. Position plants that cool during the day near spaces that are used during these times. Position plants that cool at night in areas where cool cross-ventilation is a priority for sleeping comfort.

4. **Think about the changing climate.** Select fast-growing tree species that can survive heatwaves and droughts. Recent evidence shows many commonly planted tree species in Australian cities may not survive future climate changes. See <https://www.whichplantwhere.com.au/>

## Step 4 – Cool with water

Keeping cool by playing under a water sprinkler on a hot day is an Australian tradition. And there are other ways to use water to keep cool around the house.

Here are 4 ways to incorporate water's benefits when designing cool gardens:<sup>4</sup>

1. **Create soil profiles that provide good drainage.** This includes considering soil type and depth for good irrigation, drainage and water retention. Landscaping works during new house construction can help improve drainage and retention.
2. **Keep up the soil moisture.** Evaporation keeps the air cool, and helps plants stay healthy during dry periods. Use irrigation to maintain higher levels of soil moisture across your cool garden. Irrigate during the day to make the most of evapotranspiration, and reduce stress on shade plants and trees.
3. **Use irrigation to maximise both evaporation and cooling.** Spray irrigation supports healthy shade plants and provides moisture that cools the air.
4. **Use water to help our bodies to cool down.** Breezes and misting onto our skin boost our bodies' natural cooling mechanisms.

---

4 The cooling that can be achieved will vary depending on where you live. These strategies were designed and researched in Melbourne. It is likely that a larger air temperature reduction is possible in hotter, dryer cities like Adelaide, but the cooling will be less in tropical cities like Darwin.

Design misting systems so they cool people directly:

- Spray mist directly onto skin, rather than trying to cool the air.
- Use misting on 35–40°C days. The hotter the day, the greater the benefit.
- The cooling effect from misting is short: only 5–10 minutes. So, a smart misting system can be triggered to activate when your heat stress level starts rising.

**Tip:** Design irrigation and misting systems so that they reduce heat stress on fragile plant tissue, as well as on humans. This further supports cooling.

## Step 5 – Consider smart systems

Smart sensors continually assess the local climate, make decisions and then automatically act, such as turning on a misting or irrigation system. These smart systems can be programmed to save water and reduce air temperature.

Two options for smart systems in cool gardens:

1. **Smart irrigation control systems** that deliver irrigation when and where it is needed. This can be done at a reasonable cost by monitoring soil moisture and irrigating only as needed to keep soil moisture topped up to levels that encourage evapotranspiration.
2. **Smart misting systems** that maximise the cooling impact of misting on hot days and when you want to be outside. A smart misting system could also be personalised to activate misting only when the level of heat stress drifts outside your 'comfortable' range.

# Tools for cooling

01

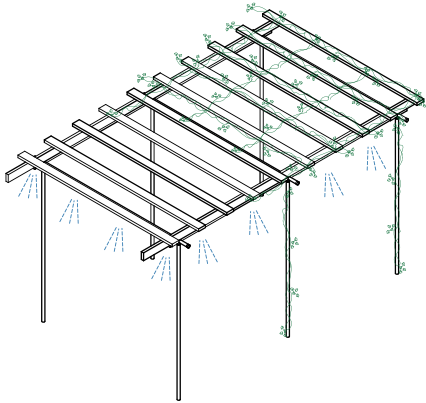

02

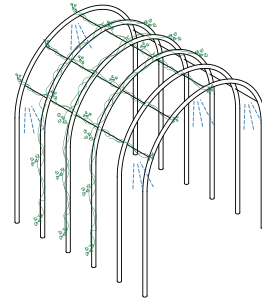

03

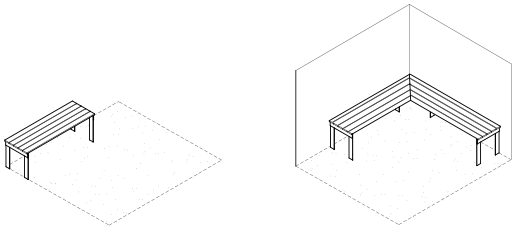

04

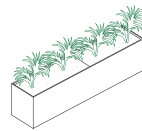

05

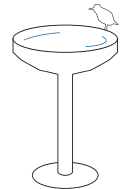

06

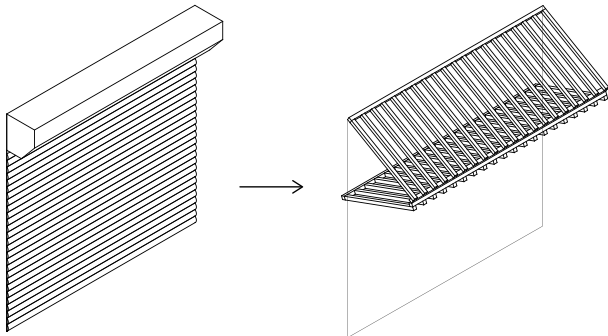

07

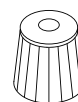

08

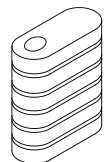

09

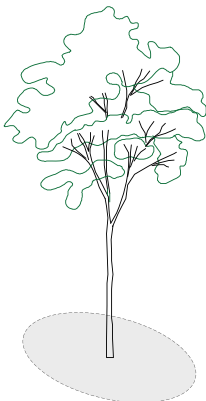

- 01. Pergola frame with misting + planting
- 02. Arbour frame with misting + planting
- 03. Timber bench seat
- 04. Planter boxes
- 05. Habitat
- 06. Retrofitting the garage
- 07. Compost bins
- 08. Water tanks
- 09. Shade tree
- 10. Downpipe diversion
- 11. Raingardens
- 12. Green walls and green roofs

Figure 5 - Cool tool kit

Now that you understand the science of sustainable cooling, and how this can be applied in 5 steps, you'll need some cooling features to use in your design.

This section outlines a 'tool kit' of cooling features you can combine to design your cool garden.

Most of these features can be easily retrofitted into existing outdoors spaces. Alternatively, you might use them as key features in a bigger landscape design.

The tool kit (Figure 5) includes:

- water systems, such as irrigation and misting systems, water tanks
- vegetation, such as ground covers, shrubs, trees or food gardens
- architectural elements, such as pergolas, arbour frames, planter boxes and benches.

Table 1 shows how these elements can be used together to provide or support shade, evapotranspiration, soil moisture or garden amenity.

10

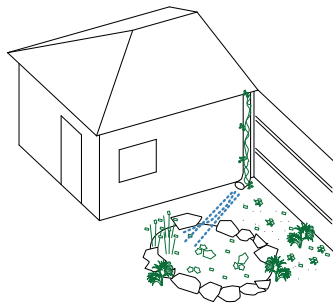
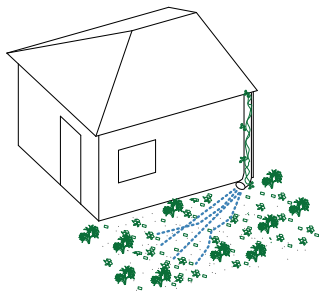

11

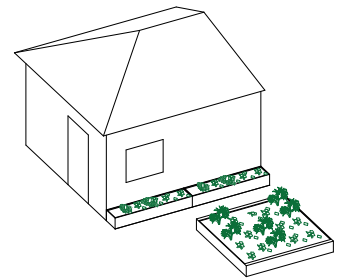

12

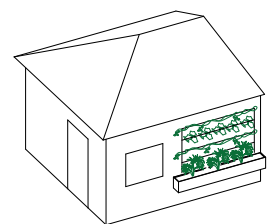
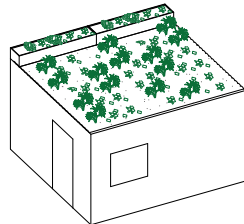
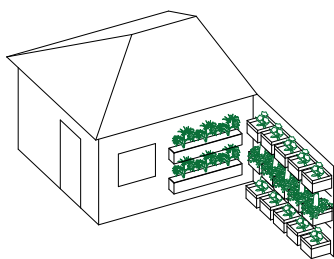

Table 1. Cool tool kit combinations

	↓ PROVIDES ↓			
	Shade	Evapotranspiration	Soil moisture	Amenity, biodiversity garden utilities
Pergola frame, with misting and planting	●	●		●
Arbour frame, with misting and planting	●	●		●
Timber bench seat				●
Planter boxes	●	●		
Compost bins			●	●
Water tanks		●	●	●
Retrofitting the garage	●			
Shade tree	●			●
Habitat		●		●
Down pipe diversion			●	
Raingardens			●	
Green Walls and green roofs	●	●		●
	Shade	Evapotranspiration	Soil moisture	Amenity, biodiversity garden utilities
	↑ SUPPORTS ↑			



# Plants for cooling

Choosing the plants for cooling is part of the garden design process. Some plants provide more shade, while others are better for cooling the air through evapotranspiration. This section helps you identify which to choose and where to put them.





































Good garden design balances the aesthetic, function, form and cooling value of plants.

Here are 3 design steps:

1. **Choose plants to match the space**, and how you will use it.
2. **Select plants for their cooling attributes**, such as shade or providing evapotranspiration at important times of day. Table 2 recommends suitable species for cool gardens, and their cooling attributes:
  - Where to use the plant: front yard, backyard, courtyard?
  - How much sun or shade it needs: full sun or part shade?
  - Does it provide best cooling during the day or the night?
3. **Species diversity is also key.** Having a diversity of species ensures different plants provide cooling at different times of the day. This helps to extend the duration of the cooling effect. Including some native species supports biodiversity.

Table 2. Plants that help cooling, and how they might be used in a cool garden design

Botanical name	Common name	Yard type	Sun/shade	Day/night cooling
<b>Trees</b>				
<i>Acer palmatum</i>	Japanese Maple	F B		
<i>Cercis canadensis</i>	Eastern Redbud	F B C		
<i>Cornus florida</i>	Flowering Dogwood	F B C		
<i>Corymbia ficifolia</i>	Flowering Gum	F B		
<i>Cupressus leylandii</i>	Leylandii	F B C		
<i>Magnolia grandiflora</i>	Southern Magnolia	F B		
<b>Fruit Trees</b>				
<i>Citrus latifolia</i>	Tihiti Lime	F B C		
<i>Citrus limon</i>	Lemon 'Lisborn'	F B C		
<i>Citrus x sinensis</i>	Orange 'Navel'	F B C		
<i>Prunus persica</i> 'Nectarine'	Nectarine 'Fantasia'	F B C		
<i>Prunus persica</i> 'Peach'	Peach 'Anzac'	F B C		
<i>Prunus domestica</i> subsp.	Plum 'Damson'	F B C		
<b>Shrubs</b>				
<i>Eutaxia microphylla</i>	Common Eutaxia	F B C		
<i>Hardenbergia violacea</i>	Purple Coral Pea	F B C		
<i>Lampranthus deltoides</i>	Deltoid-leaved dew plant	F B C		
<i>Murraya paniculata</i>	Orange Jessamine	F B C		
<i>Pittosporum Tenuifolium</i>	Black Matipo	F B C		
<i>Portulacaria afra</i>	Elephant Bush	F B C		
<i>Syzygium paniculata</i>	Backyard Bliss	F B C		
<i>Syzygium smithii</i>	Lilly Pilly	F B C		
<i>Viburnum tinus</i>	Laurustinus	F B C		
<i>Westringia fruticosa</i>	Native Rosemary/ Grey	F B C		

Botanical name	Common name	Yard type	Sun/shade	Day/night cooling
<b>Ground Cover</b>				
<i>Aptenia cordifolia</i>	Heartleaf Iceplant	F B C		
<i>Carpobrotus modestus</i>	Inland Pigface	F B C		
<i>Chamaemelum nobile</i>	Roman Chamomile	F B C		
<i>Dymondia margaretae</i>	Silver Carpet	F B C		
<i>Galium odoratum</i>	Woodruff	F B C		
<i>Isotoma axillaris</i>	Rock Isotome	F B C		
<i>Kleinia mandraliscae</i>	Blue Chalksticks	F B C		
<i>Mentha requienii</i>	Corsican Mint	F B C		
<i>Ophiopogon japonicus</i>	Mondo Grass	F B C		
<i>Sagina subulata</i>	Irish Moss	F B C		
<i>Sedum spurium</i>	Caucasian stonecrop	F B C		
<i>Soleirolia soleirolii</i>	Baby's Tears	F B C		
<i>Zygophyllum billardierei</i>	Coast Twin-leaf	F B C		
<b>Raingarden Plants</b>				
<i>Baloskion tetraphyllum</i>	Tassell Cord Rush	F B C		
<i>Carex appressa</i>	Tall Sedge	F B C		
<i>Ficinia nodosa</i>	Knotted Club-Rush	F B C		
<i>Kniphofia 'winter cheer'</i>	Red Hot Poker	F B C		
<i>Limonium perezii</i>	Sea Lavender	F B C		
<i>Poa sieberiana</i>	Grey Tussock-Grass	F B C		

# Front yard, backyard and courtyard examples

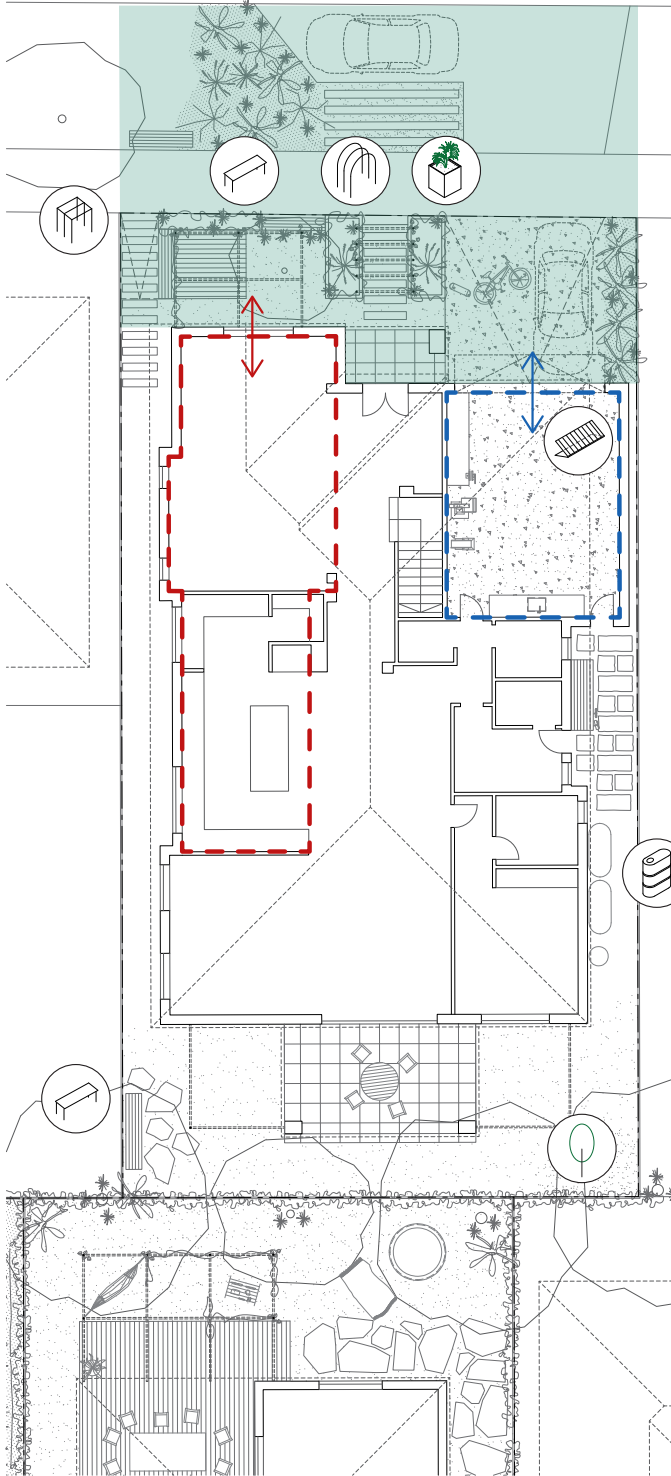

TYPE A -Frontyard

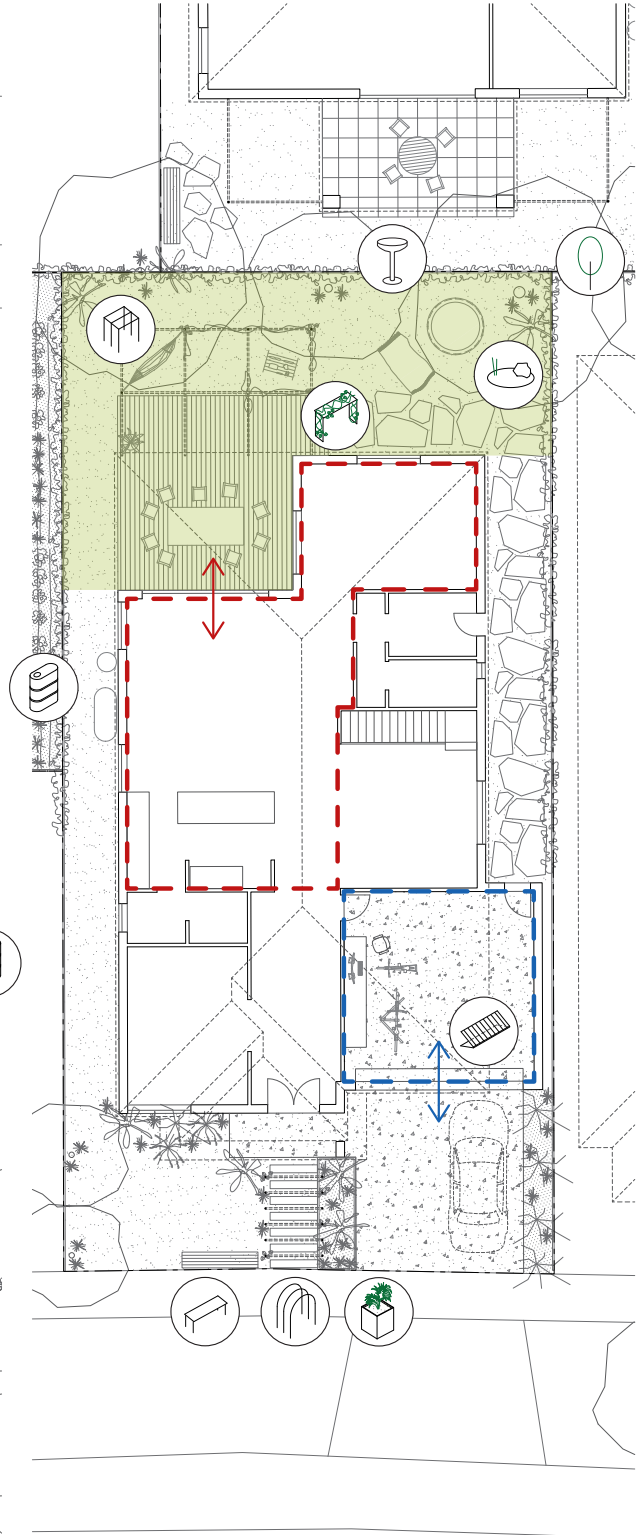

TYPE B -Backyard

Some ways to combine the cooling strategies are shown in the following cool garden examples. Each example:

- shows a cool garden designed for a different location on a block, based on a typical house design found in new suburban developments, following step 1 in this guide

- suggests cool garden designs, created by following steps 2–5 in this guide
- highlights the opportunities to connect these cool garden spaces with living spaces inside the house to increase the comfortable living areas available on hot days.

Type of outdoor spaces based on orientation

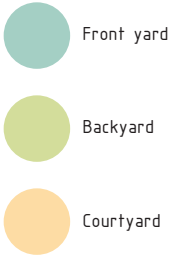

Relationship building between spaces

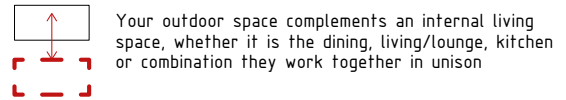

Garages more than a storage space

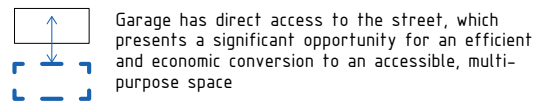

Features to add to enhance cooling

- |  |   |  |                             |  |                                 |
|--|---|--|-----------------------------|--|---------------------------------|
|  | 01. Pergola frame with misting + planting |  | 05. Compost bins            |  | 09. Habitat                     |
|  | 02. Arbour frame with misting + planting  |  | 06. Water tanks             |  | 10. Downpipe diversion          |
|  | 03. Timber bench seat                     |  | 07. Retrofitting the garage |  | 11. Raingardens                 |
|  | 04. Planter boxes                         |  | 08. Shade tree              |  | 12. Green walls and green roofs |

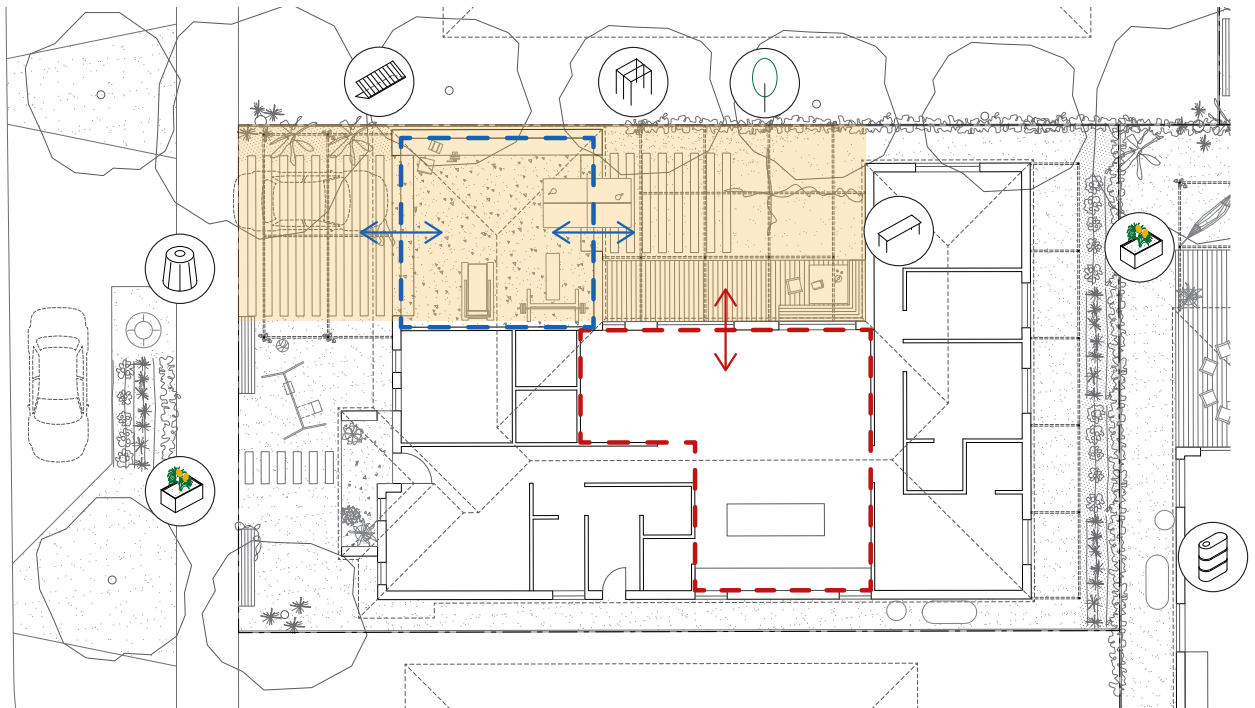

TYPE C -Courtyard

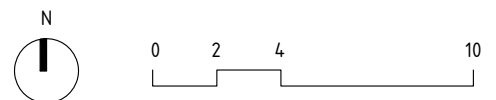

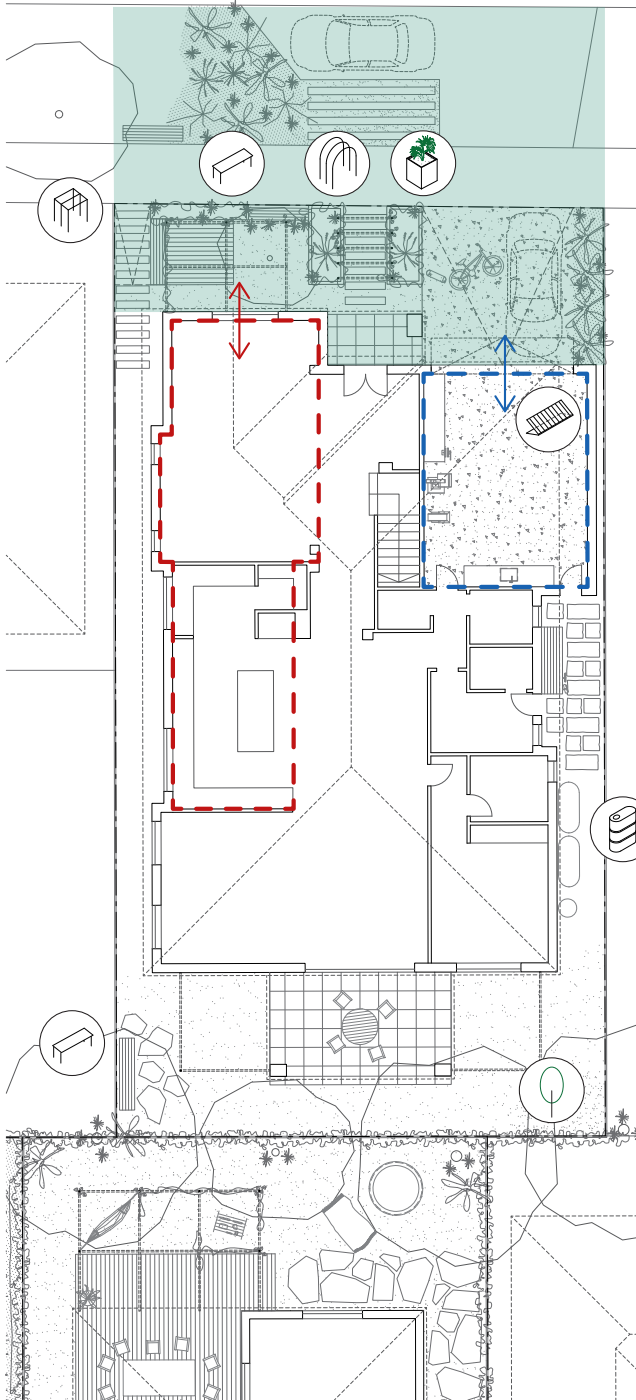

## A cool front yard

A cool front yard encourages use of this otherwise underutilised space, and creates opportunities to interact with neighbours, to enhance the sense of local community or to take advantage of views of adjacent parks.

The key is making the front yard an enjoyable place to spend time on hot days, as well as balancing the need for some privacy. Adding features such as plants, a trellis and planter boxes achieves this.

Water systems also help to create a pleasant climate. This could include directing downpipes to raingardens or to passively water trees. Smart irrigation systems can be used to maintain soil moisture and healthy plants, or to control a misting system.

The design shown connects the cool outdoor space to the internal living areas of the house. The open garage (blue dashed line in Figure 6) is set up as a recreational or entertainment space, connected to the rest of the house (red dashed line). The tilting garage door (instead of a roller door) creates extra shade and a misting system immediately in front of the garage further extends the cool space.

Figure 6. Cool front yard typology

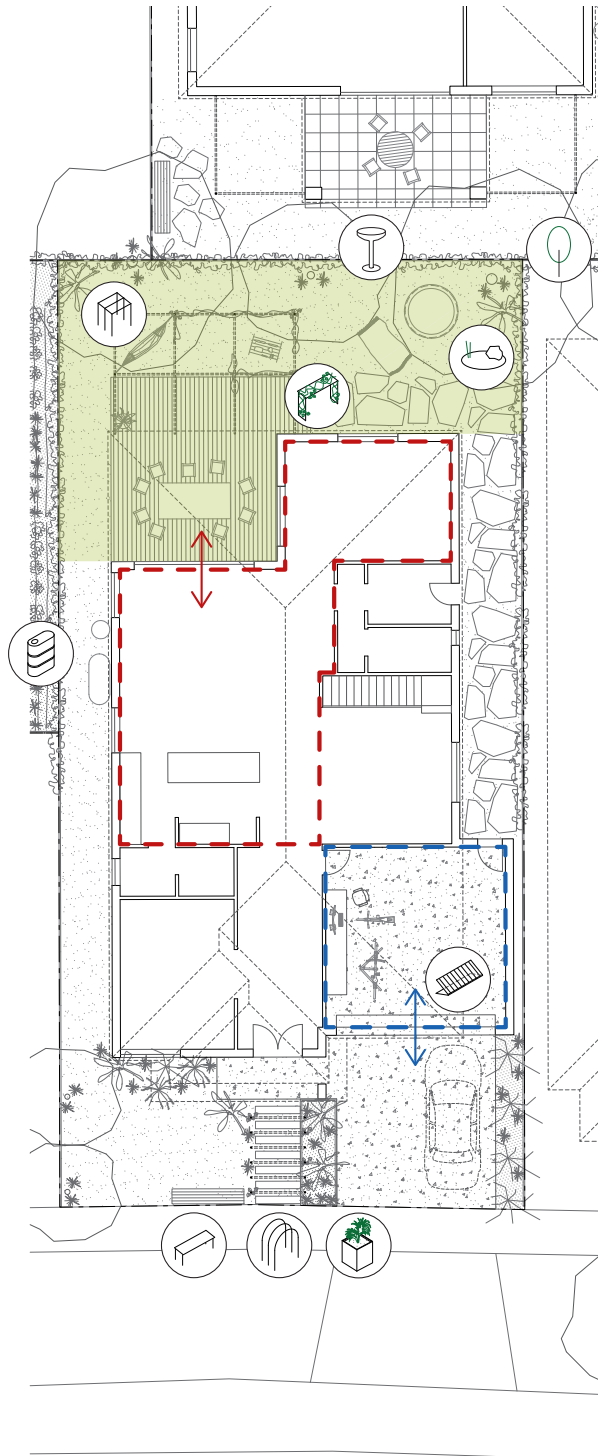

Figure 7. Cool backyard typology

## A cool backyard

We use our backyards in many different ways: gardens, growing food, children's play areas and outdoor kitchens.

Adding cooling might be a matter of enhancing an existing garden area so it can be used on hot days. For example, adding a misting system and a hammock to a pergola creates a relaxed outdoor living area for summer.

In many backyards, a shade tree is the central cooling feature. You can use water systems to help the tree grow quickly, stay healthy and provide evapotranspiration for cooling. The cool area can be extended by adding smart irrigation systems to irrigate the lawn surrounding the tree.

If a tree is not an option (e.g. Figure 7), a cool backyard area can be created by adding features such as a trellis, arbour, green walls or well-watered garden beds. These features can complement overhead misting systems added to an existing outdoor entertainment area, along with well-irrigated gardens to cool the surrounding ground surface. These cooling features make the entertainment area more enjoyable on hot days, and help shield the walls of the house from the sun's radiant heat.



## A cool courtyard

The cool courtyard is designed as both an outdoor entertaining area and a transition area connecting to the multipurpose garage (blue dashed line in Figure 8) and the internal living areas (red dashed line). This maximises the available living area on hot days, removing the need to escape the heat indoors.

The design uses suitable shade trees along the boundary or in pots and planters, and overhead structures to create shade. Surface areas are broken up with a mix of garden beds to minimise hard surfaces that absorb heat. Green walls and misting systems complement the cooling effect.

Other areas around the house can be used for food gardens in planter boxes or to locate rainwater tanks to enhance sustainable living, providing a sustainable water supply for irrigation systems. Misting systems should always be connected to the household mains water supply, for health reasons.

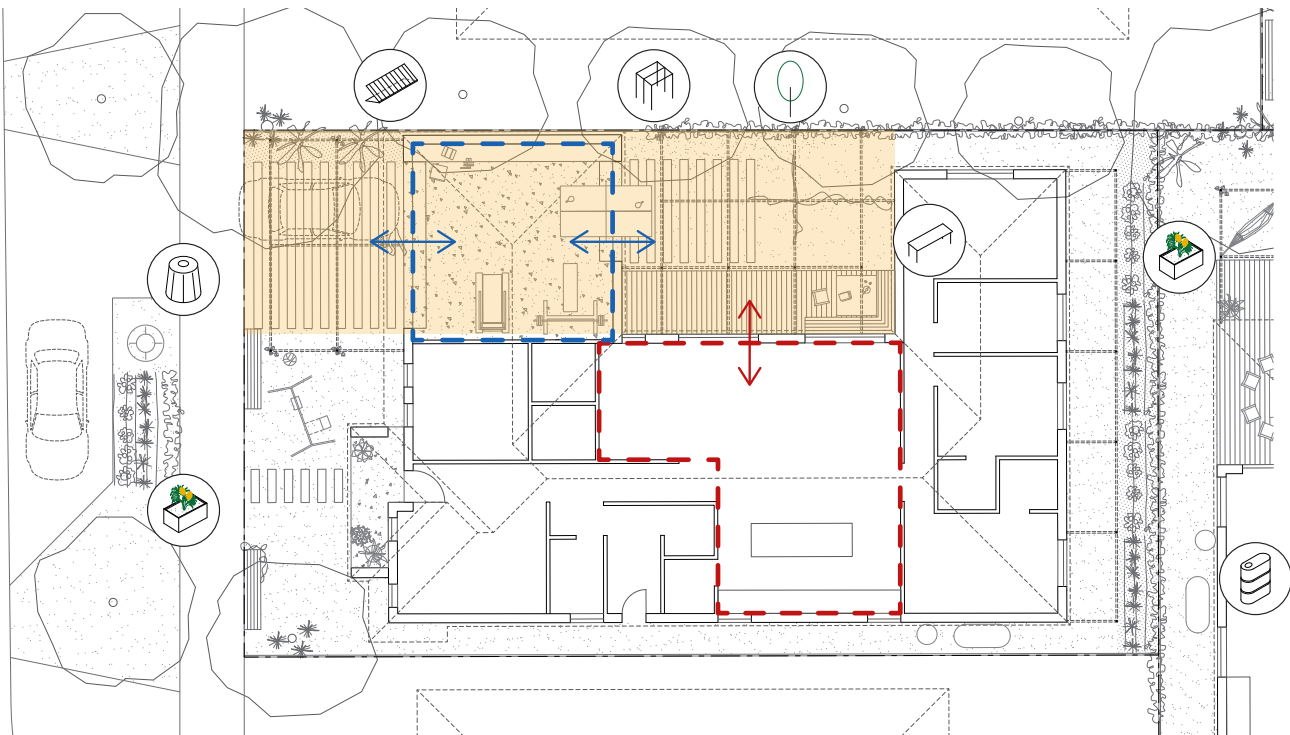

Figure 8. Cool courtyard typology



# References

- Aecom (2012). [Economic Assessment of the Urban Heat Island Effect](#), Report for City of Melbourne. Melbourne, Australia: Aecom.
- Bouchama A., Dehbi M., Mohamed G., Matthies F., Shoukri M. and Menne B. (2007). Prognostic factors in heat wave-related deaths: a metaanalysis. *Archives of Internal Medicine*, 167: 2170–76.
- Broadbent A.M., Coutts A.M., Tapper N.J. and Demuzere M. (2017). The cooling effect of irrigation on urban microclimate during heatwave conditions. *Urban Climate*, 23: 309–329.
- Bureau of Meteorology (2023). [Bureau of Meteorology](#). Canberra, Australia: BOM.
- Cheung P., Nice K. and Livesley S. (2022a). Irrigating urban green space for cooling benefits: the mechanisms and management considerations. *Environmental Research: Climate*, 1(1), 015001.
- Cheung P., Jim C., Tapper N., Nice K. and Livesley S. (2022b). Daytime irrigation leads to significantly cooler private backyards in summer. *Urban Climate*, 46: 101310.
- Coates L., Haynes K., O'Brien J., McAneney J. and Dimer de Oliveira F. (2014). Exploring 167 years of vulnerability: An examination of extreme heat events in Australia 1844–2010. *Environmental Science & Policy*, 42.
- Coutts A., Tapper N., Beringer J., Daly E., White E., Broadbent A., Pettigrew J., Harris R., Gebert L., Nice K., Hamel P., Fletcher T. and Kalla M. (2013). [Determine the microclimate influence of harvesting solutions and water sensitive urban design at the micro-scale: green cities and microclimate](#). Melbourne, Australia: CRC for Water Sensitive Cities.
- Coutts A., Tapper N., Loughnan M., Demuzere M., Broadbent A., Motazedian A., White E., Phan T., Thom J., Gebert L. and Pankhina D. (2015). [Determine the microclimatic influence of harvesting solutions and WSUD at the micro-scale](#). Melbourne, Australia: CRC for Water Sensitive Cities.
- Coutts A and Tapper N. (2017). [Trees for a Cool City: Guidelines for optimised tree placement](#). Melbourne, Australia: CRC for Water Sensitive Cities.
- CRC for Water Sensitive Cities (2018). [Aquarevo: a smart model for residential water management](#). Melbourne, Australia: CRC for Water Sensitive Cities. Department of Human Services (2009). *January 2009 heatwave in Victoria: an assessment of health impacts*. Melbourne, Australia: DHS.
- Jay O., Capon A., Berry P., Broderick C., de Dear R., Havenith G., Honda Y., Sari Kovats R., Ma W., Malik A., Morris N., Nybo L., Seneviratne S., Vanos K.J. and Ebi K. (2021). Reducing the health effects of hot weather and heat extremes: from personal cooling strategies to green cities. *Lancet*, 398: 709–24.
- Lindstrom S.J., Nagalingam V. and Newnham H.H. (2013). Impact of the 2009 Melbourne heatwave on a major public hospital. *Internal Medicine Journal*, 43: 1246–1250.
- Loughnan M.E., Tapper N.J., Phan T., Lynch K. and McInnes J.A. (2013). [A spatial vulnerability analysis of urban populations during extreme heat events in Australian capital cities](#). Gold Coast, Australia: National Climate Change Adaptation Research Facility.
- McEvoy D., Ahmed I. and Mullett J. (2012). The impact of the 2009 heat wave on Melbourne's critical infrastructure. *Local Environment*, 17(8): 783–796.
- Nice K. (2021). [Managing urban heat in water sensitive cities: research and policy responses](#). Melbourne, Australia: Cooperative Research Centre for Water Sensitive Cities.
- Nicholls N., Skinner C., Loughnan M. and Tapper N. (2008). A simple heat alert system for Melbourne, Australia. *International Journal of Biometeorology*, 52: 375–384.
- Osmond P. and Sharifi E. (2017). [Guide to Urban Cooling Strategies](#). Sydney, Australia: Low Carbon Living CRC.
- Ossola A., Staas L. and Leishman M.R. (2020). [Urban Trees and People's Yards Mitigate Extreme Heat in Western Adelaide](#). Sydney, Australia: Macquarie University.
- Rey G., Fouillet A., Bessemoulin P., et al. (2009). Heat exposure and socioeconomic vulnerability as synergistic factors in heatwaverelated mortality. *European Journal of Epidemiology*, 24: 495–502.
- South East Water (2023). [Aquarevo](#). Melbourne, Australia: SEW.
- Sydney Water and University of New South Wales (2017). [Cooling Western Sydney](#). Sydney, Australia: Sydney Water.
- Western Sydney Regional Organisation of Councils, Resilient Sydney and the Greater Sydney Commission (2022). [Cool Suburbs, User Guide and science rationale](#). Sydney, Australia: WSROC.





